

Reactions of B Atoms with NH₃ To Produce HBⁿNH, BⁿNBH, and B₂N

Craig A. Thompson and Lester Andrews*

Department of Chemistry, University of Virginia
Charlottesville, Virginia 22901

Received April 18, 1995

Laser ablation has proven to be valuable for studying boron atom reactions with small molecules such as O₂, H₂O, N₂, H₂, CH₄, and C₂H₂ to produce and characterize new molecules and to understand reaction mechanisms.^{1–9} Boron–methane studies identified novel HBCH₂ and HBCH products of the insertion reaction followed by dehydrogenation; the reaction of a second boron atom gave HCBCH. In the case of acetylene, boron atom C≡C addition and C–H insertion products were observed and characterized.^{8,9}

The simplest iminoborane, HBNH, is isoelectronic with acetylene, and similar reactions with boron atoms are expected. However, HBNH is extremely reactive, and only two experimental observations of HBNH have been reported, a matrix photolysis of H₃BNH₃ and a gas phase discharge of B₂H₆/NH₃ mixtures.^{10,11} The boron–methane studies predict that the elusive HBNH molecule will be a major product of the boron–ammonia reaction, and the boron–acetylene work suggests that further reactions will give linear and cyclic secondary reaction products, which will be reported here.

The pulsed-laser ablation matrix-isolation technique has been described.^{1–4} Mixtures of argon/ammonia (1% and less) were codeposited with laser-ablated boron atoms onto a 10 ± 1 K optical window. Natural abundance (¹⁴NH₃, 80.4% ¹¹B–19.6% ¹⁰B) and isotopically enriched precursors (¹⁵NH₃, ND₃, 93.8% ¹⁰B–6.2% ¹¹B) were employed. Infrared spectra were recorded at 0.5 cm⁻¹ resolution using a Nicolet 750 with MCT detector.

Figure 1 shows spectra of the major product absorptions in the diagnostic spectral regions. The sharp ⁿB doublet at 1788.7, 1782.8 cm⁻¹ and the weaker (1:4) counterpart at 1826.3, 1819.9 cm⁻¹ (Figure 1c) are due to the B–N stretching fundamental of H¹BⁿNH and H¹⁰BⁿNH in natural abundance site split by the matrix. Figure 1a shows spectra for the ¹⁰B reaction, and the latter doublet is enhanced, but the former doublet is still observed owing to 6.2% ¹¹B in the ¹⁰B-enriched sample. The spectrum for ¹⁰B and ¹⁴NH₃/¹⁵NH₃ is illustrated in Figure 1b, and new bands were observed at 1804.6, 1798.3 cm⁻¹ for H¹⁰B¹⁵NH. Analogous bands were observed at 1766.2, 1760.3 cm⁻¹ for H¹¹B¹⁵NH in a ⁿB isotopic experiment. Stronger bands were observed at 3710.5, 3700.5 cm⁻¹ (NH stretch) and 463.3, 461.0 cm⁻¹ (NH bend) for HBNH in agreement with earlier work; the assignments are confirmed by ¹⁵N shifts and ab initio frequency calculations.

The strongest feature in the spectrum exhibits a 1:8:16 triplet at 901.5, 891.1, 882.1 cm⁻¹ with ⁿB (absorbance 0.4–0.7) and a mixed ¹⁴N/¹⁵N doublet at 901.5, 881.8 cm⁻¹ with ¹⁰B (not shown). This band system has been produced from ablated BN and from ablated B + N₂ reactions and identified as the cyclic

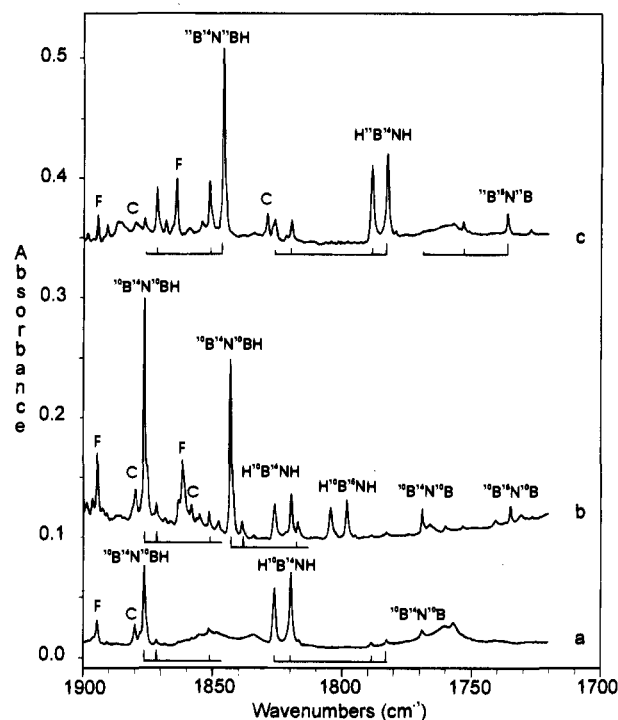

Figure 1. Infrared spectra in the B–N stretching region 1900–1725 cm⁻¹ for pulsed-laser ablated boron atom–ammonia–argon samples condensed at 10 ± 1 K: (a) ¹⁰B + ¹⁴NH₃, (b) ¹⁰B + ¹⁴NH₃/¹⁵NH₃, and (c) ⁿB + ¹⁴NH₃. Horizontal lines indicate boron isotopic multiplets (including site splittings for HBNH).

azadiboriridine radical B₂N with two equivalent B atoms.³ A weaker 1:8:16 triplet at 1769.1, 1753.4, 1736.4 cm⁻¹ is due to the linear BNB radical.³ The weaker C and F bands are due to minor reaction products that will be identified in a complete experimental and theoretical report.

The next strongest band gives a new 1:4:4:16 quartet at 1876.4, 1871.8, 1851.5, 1846.3 cm⁻¹ with ⁿB (Figure 1c) denoting the vibration of two inequivalent B atoms; in the ¹⁰B experiment (Figure 1a) the former three bands were observed as a 88:6:6 triplet with lower weights for the boron-10,11 isotopic species. A mixed ¹⁴N/¹⁵N doublet (Figure 1b) showed the involvement of a single N atom, and displacement with ND₃ verified the presence of hydrogen in this new species. Observed isotopic frequencies for this antisymmetric B–N–B stretching fundamental and weaker symmetric B–N–B stretching, B–H stretching and bending modes associated by common photolysis behavior (5% growth) are listed in Table 1.

The identification of linear BNBH from isotopic infrared spectra is confirmed by SCF calculations¹² of isotopic frequencies and intensities, which are also listed in Table 1. Typically SCF calculations produce frequencies that are about 10% higher than observed values as is the case for BNBH. However, the excellent agreement between observed and calculated isotopic frequencies is found in the observed:calculated frequency ratios given in the table for four isotopic BNBH molecules. First, note that the ratios are extremely close (0.928–0.941) for the three stretching modes (all isotopes) but slightly lower for the linear bending mode (0.881) as the latter mode is more anharmonic. Second, note that the deviation in isotopic frequency ratios for the N–H stretch (±0.0002) gives a ±0.6 cm⁻¹ frequency fit. The deviations in ratios for the antisymmetric B–N–B stretch (±0.0004) and symmetric counterpart (±0.0007) show ±0.8 cm⁻¹ frequency agreement. The deviation (±0.0003) in ratios for the N–H bending mode produces

(1) Burkholder, T. R.; Andrews, L. *J. Chem. Phys.* **1991**, *95*, 8697.
 (2) Andrews, L.; Burkholder, T. R. *J. Phys. Chem.* **1991**, *95*, 8554.
 (3) Andrews, L.; Hassanzadeh, P.; Burkholder, T. R.; Martin, J. M. L. *J. Chem. Phys.* **1993**, *98*, 922.
 (4) Hassanzadeh, P.; Andrews, L. *J. Phys. Chem.* **1992**, *96*, 9177.
 (5) Tague, T. J., Jr.; Andrews, L. *J. Am. Chem. Soc.* **1994**, *116*, 4970.
 (6) Hassanzadeh, P.; Andrews, L. *J. Am. Chem. Soc.* **1992**, *114*, 9239.
 (7) Hassanzadeh, P.; Hannachi, Y.; Andrews, L. *J. Phys. Chem.* **1993**, *97*, 6418.
 (8) Martin, J. M. L.; Taylor, P. R.; Hassanzadeh, P.; Andrews, L. *J. Am. Chem. Soc.* **1993**, *115*, 2510.
 (9) Andrews, L.; Hassanzadeh, P.; Martin, J. M. L.; Taylor, P. R. *J. Phys. Chem.* **1993**, *97*, 5839.
 (10) Lory, E.; Porter, R. *J. Am. Chem. Soc.* **1973**, *95*, 1767.
 (11) Kawashima, Y.; Kawaguchi, K.; Hirota, E. *J. Chem. Phys.* **1987**, *87*, 6331.

(12) Stanton, J. F.; Gauss, J.; Watts, J. D.; Lauderdale, W. J.; Bartlett, R. J. *ACESII, an Ab Initio System, Quantum Theory Project*; University of Florida: Gainesville, FL, 1994.

Scheme 1. Laser-Ablated Boron Plus Ammonia Reaction Mechanism

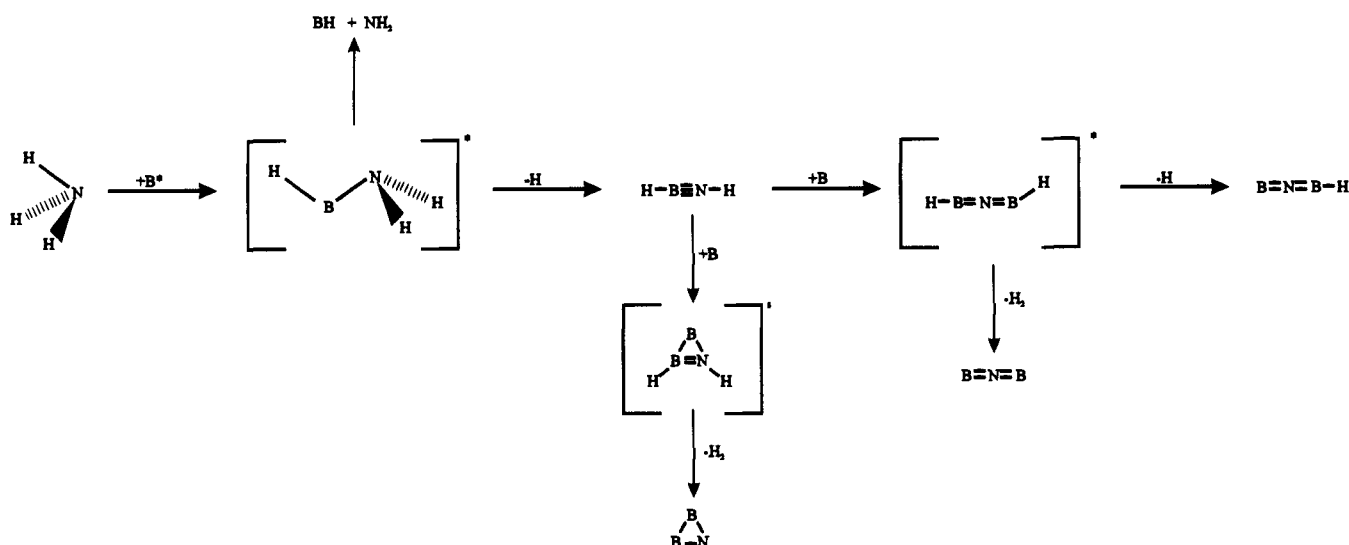
**Table 1.** SCF Calculated and Observed Isotopic Frequencies (cm^{-1}) for Linear BNBH

| | $\nu(\text{B-H})$ | $\nu_2(\text{B-N-B})$ | $\nu_3(\text{B-N-B})$ | $\delta(\text{N-B-H})$ | $\delta(\text{B-N-B})$ |
|--|-------------------|-----------------------|-----------------------|------------------------|------------------------|
| $^{11}\text{B}^{14}\text{N}^{11}\text{BH}$ | 2981.4 | 1988.9 | 1159.3 | 847.0 | 158.2 |
| observed | 2805.6 | 1846.3 | 1089.3 | 746.2 | |
| ratio | 0.9410 | 0.9283 | 0.9396 | 0.8810 | |
| I (km/mol) ^b | [94] | [947] | [118] | [2 × 24] | [2 × 0.3] |
| I (observed) ^c | [0.004] | [0.160] | [0.014] | [0.009] | |
| $^{10}\text{B}^{14}\text{N}^{11}\text{BH}$ | 2981.4 | 1993.9 | 1196.1 | 847.0 | 159.9 |
| observed | 2805.6 | 1851.5 | | 746.2 | |
| $^{11}\text{B}^{14}\text{N}^{10}\text{BH}$ | 3004.9 | 2016.0 | 1173.7 | 857.0 | 158.9 |
| observed | 2826.9 | 1871.4 | | 754.5 | |
| $^{10}\text{B}^{14}\text{N}^{10}\text{BH}$ | 3004.9 | 2020.5 | 1210.9 | 857.0 | 160.6 |
| observed | 2826.9 | 1876.4 | 1136.4 | 754.5 | |
| ratio | 0.9408 | 0.9287 | 0.9385 | 0.8805 | |
| I (km/mol) | [114] | [957] | [133] | [2 × 26] | [2 × 0.3] |
| $^{11}\text{B}^{15}\text{N}^{11}\text{BH}$ | 2980.3 | 1951.1 | 1157.5 | 846.0 | 155.1 |
| observed | 2805.1 | 1812.3 | 1087.2 | 745.2 | |
| ratio | 0.9412 | 0.9289 | 0.9393 | 0.8809 | |
| I (km/mol) | [88] | [903] | [121] | [2 × 24] | [2 × 0.3] |
| $^{10}\text{B}^{15}\text{N}^{11}\text{BH}$ | 2980.3 | 1956.0 | 1194.7 | 846.0 | 156.8 |
| observed | 2805.1 | 1817.2 | | 746.0 | |
| $^{11}\text{B}^{15}\text{N}^{10}\text{BH}$ | 3003.5 | 1979.5 | 1171.4 | 855.9 | 155.9 |
| observed | 2826.2 | 1838.8 | | 753.5 | |
| $^{10}\text{B}^{15}\text{N}^{10}\text{BH}$ | 3003.5 | 1983.9 | 1209.0 | 855.9 | 157.5 |
| observed | 2826.2 | 1843.3 | 1134.2 | 753.5 | |
| ratio | 0.9409 | 0.9291 | 0.9381 | 0.8804 | |
| $^{11}\text{B}^{14}\text{N}^{11}\text{BD}$ | 2368.8 | 1833.3 | 1134.9 | 677.4 | 150.6 |
| observed | 2218.7 | 1717.6 | 1062.4 | 596.4 | |
| ratio | 0.9366 | 0.9369 | 0.9361 | 0.8804 | |
| I (km/mol) | [447] | [615] | [97] | [2 × 25] | [2 × 0] |
| $^{10}\text{B}^{14}\text{N}^{11}\text{BD}$ | 2369.3 | 1839.7 | 1169.9 | 677.4 | 152.4 |
| observed | 2219.7 | 1723.8 | | 596.4 | |
| $^{11}\text{B}^{14}\text{N}^{10}\text{BD}$ | 2418.6 | 1837.5 | 1147.4 | 689.9 | 150.9 |
| observed | 2262.3 | 1723.2 | 1074.0 | | |
| $^{10}\text{B}^{14}\text{N}^{10}\text{BD}$ | 2419.1 | 1843.6 | 1182.8 | 689.9 | 152.6 |
| observed | 2263.2 | 1729.0 | | 596.4 | |

^a Using 6-311G* basis sets. ^b Using calculated infrared intensities. ^c Using observed band absorbances.

$\pm 0.3 \text{ cm}^{-1}$ agreement. The observed band absorbances, relative to one another, agree well with the calculated infrared intensities except for the B-H stretch, which is weaker than predicted at the SCF level of theory. Finally, the observed:calculated frequency ratios for BNBD are slightly different owing to differences in anharmonicity and normal coordinate vibrational motion.

The matrix chemistry reported here is significant since the simplest and most reactive iminoborane, HBNH, and its further reactions with the simplest boron reagent, atomic B, have been examined. Scheme 1 outlines the major reactions observed here. The insertion of boron into a N-H bond requires activation

energy provided by the hyperthermal ablated B atoms; the $[\text{HBNH}_2]^*$ species formed contains excess energy, which activates hydrogen elimination to give HBNH. Iminoborane, the acetylene analog, trimerizes to give borazine, $\text{H}_3\text{B}_3\text{N}_3\text{H}_3$, the benzene analog, under normal conditions,¹³ but here the condensing argon matrix prevents this reaction. However, secondary reactions with B atoms proceed as expected following addition and insertion reactions with $\text{B} + \text{HCCH}$ to give $\text{H}_2\text{C}_2\text{B}$ and CCBH .^{8,9} On the basis of band intensities the major secondary reaction is addition followed by H_2 elimination to give the azadiboriridine radical B_2N ; no evidence was found for $\text{H}_x\text{B}_2\text{N}$ ($x = 1, 2$) species absorbing near B_2N . In contrast the HCCH reaction yielded the borirene radical $\text{H}_2\text{C}_2\text{B}$ and not C_2B ; the latter has been observed from ablation of graphite/boron pellets.¹⁴ The difference here is presumably the greater strength of C-H bonds compared to N-H and B-H bonds since the isoelectronic C_2B and B_2N rings should be of comparable stability.

The N-H insertion reaction followed by H and H_2 elimination produces the linear BNBH and BNB species. In contrast to HBCBH in the methane reaction,⁶ there was no evidence for HBNBH; the former is a stable, allene-like species, whereas the latter is a radical precursor to the more stable BNBH molecule observed here. The yield of B_2N and BNBH in the present experiments is higher than the yield of $\text{H}_2\text{C}_2\text{B}$ and CCBH in similar acetylene reactions,^{8,9} on the basis of band intensities. Considering the obvious fact that HCCH reagent concentration in earlier work surely exceeded HBNH concentration here by at least 2 orders of magnitude, the reactivity of HBNH toward B atoms is substantially greater than the reactivity of HCCH. This is in accord with the ready formation of borazine from HBNH and the slow formation of benzene from HCCH. Iminoborane, HBNH, is clearly a stable but highly reactive molecule that can be formed in the exothermic reaction of B and NH_3 and trapped in a condensing argon matrix.

Acknowledgment. We gratefully acknowledge support for this research from the Air Force Office of Scientific Research.

JA951232E

(13) Paetzold, P. *Pure Appl. Chem.* **1991**, *63*, 345; *Adv. Inorg. Chem.* **1987**, *31*, 123.

(14) Martin, J. M. L.; Taylor, P. R.; Yustein, J. T.; Burkholder, T. R.; Andrews, L. *J. Chem. Phys.* **1993**, *99*, 12.